

NEXUS™



Playgrounds

A division of PlayPower



THE NEXT GENERATION OF PLAY EQUIPMENT HAS ARRIVED



A New Concept to Attract and Challenge Older Kids!

Developed by SMP, a division of PlayPower, **NEXUS** is specifically designed and engineered to thrill a generation of more sophisticated “tweens” ages 7-14 who resist being treated like young children.

The complex curves and angles of **NEXUS** create a modern, high-tech look that appeals instinctively to the “tweener” age group’s sense of style, adventure and need for challenging play equipment while satisfying adult concerns for safety and physical fitness. This is no “little kiddie” playground – **NEXUS** creates a place where young people will want to hang out and have fun just because it’s really cool.

Our **NEXUS** product line includes a wide range of components and configurations to fit any playground space and suit any budget. Every **NEXUS** system has been designed, manufactured and tested to meet or exceed CPSC, ASTM F1487 and EN1176 guidelines and standards.

All equipment in this brochure has been designed, manufactured, and tested to meet or exceed the strictest guidelines and standards, including ASTM F1487, CPSC and EN1176.

putting the
factor
back into
play



Want to play? Call us for details and find your local sales representative.

1-866-4PLAYPWR or visit www.playpower.com/nexus

NEXUS™ - THE CORE

NEXUS CORE is the centerpiece of our **NEXUS** product line. Kids will be challenged exploring its climbing poles, climbers, perches, nets, climbing wall and banister rails, all of which are framed by three gantry posts. **NEXUS CORE** coordinates with various **NEXUS VELOCITY** components for even more play options. Enticingly promoting vigorous activity for healthier kids, **NEXUS CORE** is never a bore!

Material Specifications

- Hot dipped galvanized steel structure
- Stainless steel and powder coated steel components
- 0.7" (18mm) steel reinforced, polyethylene covered ropes
- High density polyethylene rock face
- Tamper-proof stainless steel hardware throughout



THE CORE WITHOUT BANISTERS (10NXCBE-U)

Age range **7-14 yrs**

EQUIPMENT DIMENSIONS

Length x Width x Height - ft (m) **11'-4" x 9'-5" x 9'-10"**
(3.46 x 2.87 x 3.0)

INSTALLATION INFORMATION

Total weight - lb (kg) **1,202 (545)**
 Heaviest part - lb (kg) **163 (74)**
 Largest part - ft (m) **12'-2" x 1'-2" x 3'-2"**
 (3.73 x 0.35 x 0.40)
 Concrete footings - yd³ (m³) **1.71 (1.31)**

SURFACE & SPACE REQUIRED

Min. space L x W x H - ft (m) **23'-4" x 21'-4" x 16'-5"**
 (7.11 x 6.51 x 5.0)
 Max. Fall Height - ft (m) **9'-10" (3)**
 Use Zone Area - ft² (m²) **403 (37)**
 Perimeter - ft (m) **75' (23)**

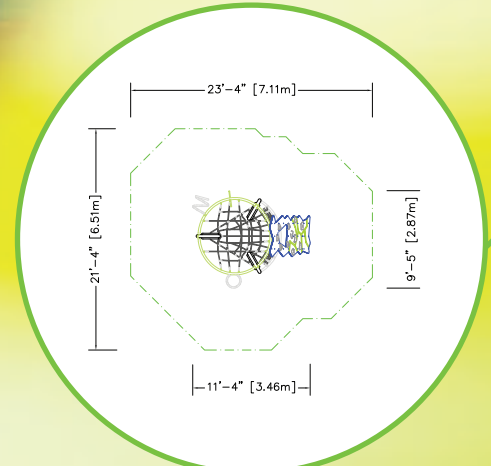

THE CORE (10NXCBE-U)

Age range **7-14 yrs**

EQUIPMENT DIMENSIONS

Length x Width x Height - ft (m) **19'-10" x 9'-5" x 9'-10"**
(6.05 x 2.87 x 3.0)

INSTALLATION INFORMATION

Total weight - lb (kg) **1,290 (585)**
 Heaviest part - lb (kg) **163 (74)**
 Largest part - ft (m) **12'-2" x 1'-2" x 3'-2"**
 (3.73 x 0.35 x 0.40)
 Concrete footings - yd³ (m³) **1.83 (1.4)**

SURFACE & SPACE REQUIRED

Min. space L x W x H - ft (m) **31'-10" x 21'-4" x 16'-5"**
 (9.71 x 6.51 x 5.0)
 Max. Fall Height - ft (m) **9'-10" (3)**
 Use Zone Area - ft² (m²) **505 (47)**
 Perimeter - ft (m) **89' (27)**

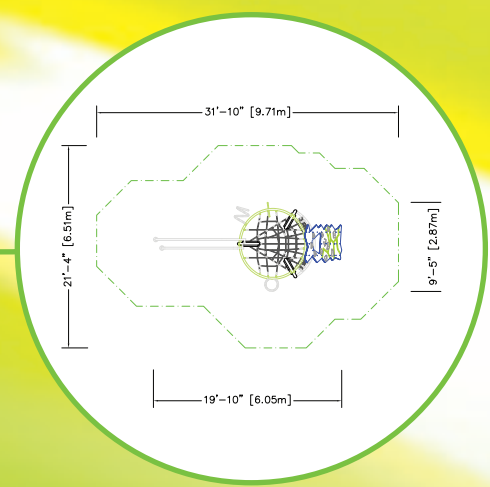

NEXUS™ - VELOCITY

NEXUS VELOCITY is all about moving fast! We satisfy the youthful need for speed with the safe and healthy activity that **NEXUS VELOCITY** generates. Kids immediately grasp the compelling challenge of maneuvering the set's perimeter without touching the ground. This product line is available in a number of distinctive configurations, many of which can be incorporated with **NEXUS CORE** or **NEXUS QUANTUM**.

For complete technical specifications and topview diagrams for all of our **NEXUS VELOCITY** product options, including our most popular and versatile **VELOCITY 7**, visit www.playpower.com/nexus.



Stand 'n' Spin



Swinging hangers with resting sphere



Scramble net (Nets are only available in black)



Spinning wheels



Sit 'n' Spin



VELOCITY

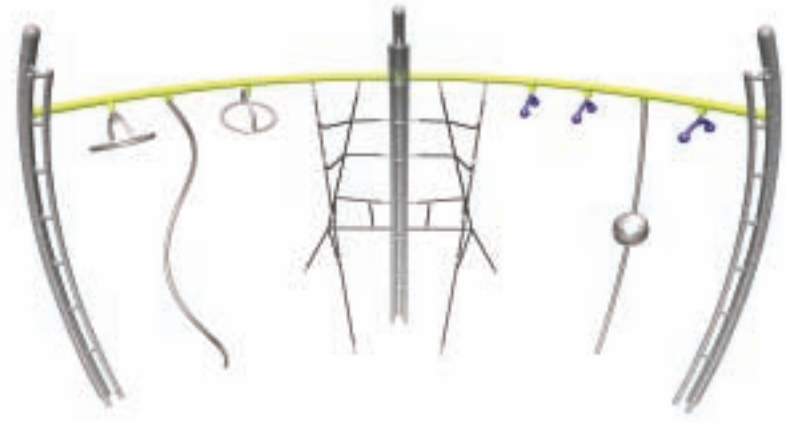

VELOCITY 1 (1000NXVE1)	
Age range	7-14 yrs
EQUIPMENT DIMENSIONS	
Length x Width x Height - ft (m)	18'-5" x 8'-4" x 9'-10" (5.61 x 2.53 x 3.0)
INSTALLATION INFORMATION	
Total weight - lb (kg)	911 (413)
Heaviest part - lb (kg)	194 (88)
Largest part - ft (m)	12'-2" x 1'-2" x 3'-2" (3.73 x 0.35 x 0.96)
Concrete footings - yd ³ (m ³)	2.20 (1.64)
SURFACE & SPACE REQUIRED	
Min. space L x W x H - ft (m)	30'-5" x 20'-4" x 16'-5" (9.27 x 6.19 x 5.0)
Max. Fall Height - ft (m)	9'-10" (3)
Use Zone Area - ft ² (m ²)	486 (45)
Perimeter - ft (m)	90' (27)

Material Specifications

- Hot dipped galvanized steel structure
- Stainless steel and powder coated steel components

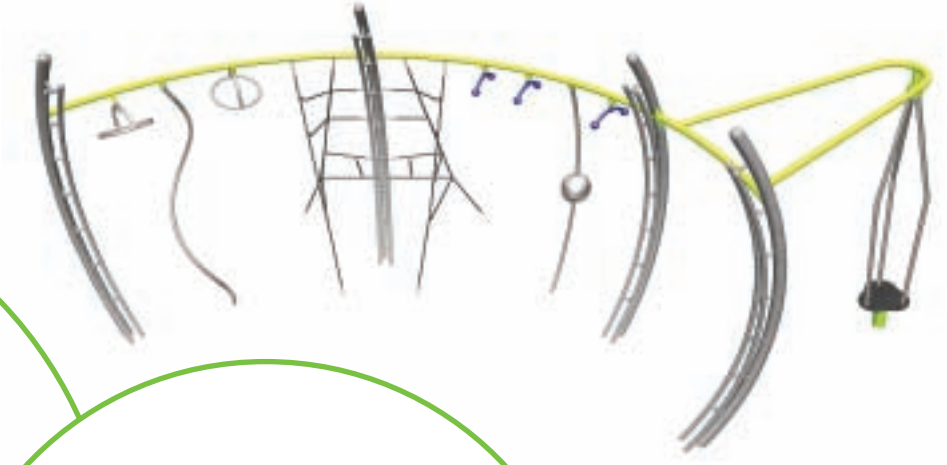

VELOCITY 3 (1000NXVE3)	
Age range	7-14 yrs
EQUIPMENT DIMENSIONS	
Length x Width x Height - ft (m)	26'-8" x 12'-7" x 9'-10" (8.13 x 3.83 x 3.0)
INSTALLATION INFORMATION	
Total weight - lb (kg)	1,455 (660)
Heaviest part - lb (kg)	194 (88)
Largest part - ft (m)	12'-2" x 1'-2" x 3'-2" (3.73 x 0.35 x 0.96)
Concrete footings - yd ³ (m ³)	3.28 (2.51)
SURFACE & SPACE REQUIRED	
Min. space L x W x H - ft (m)	38'-8" x 24'-7" x 16'-5" (11.78 x 7.48 x 5.0)
Max. Fall Height - ft (m)	9'-10" (3)
Use Zone Area - ft ² (m ²)	645 (60)
Perimeter - ft (m)	112' (34)

- 0.7" (18mm) steel reinforced, polyethylene covered ropes
- High density polyethylene rock face
- Tamper-proof stainless steel hardware throughout

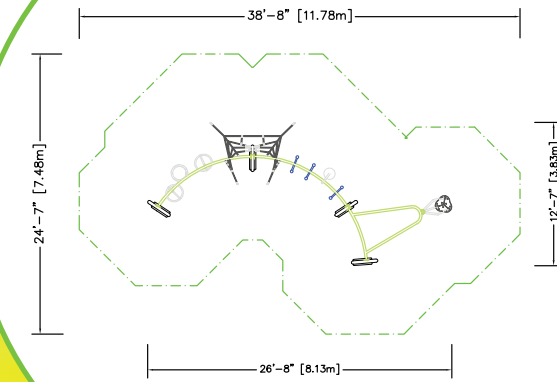
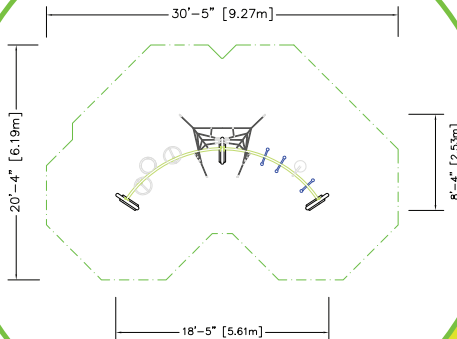

VELOCITY 1

VELOCITY 3

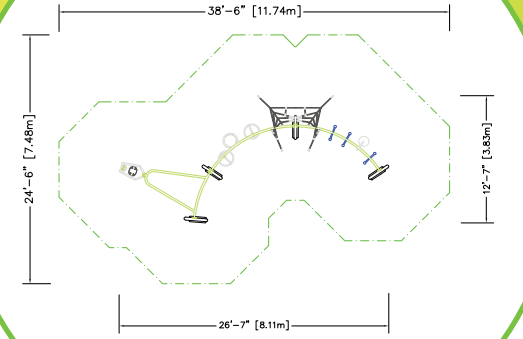

VELOCITY 2

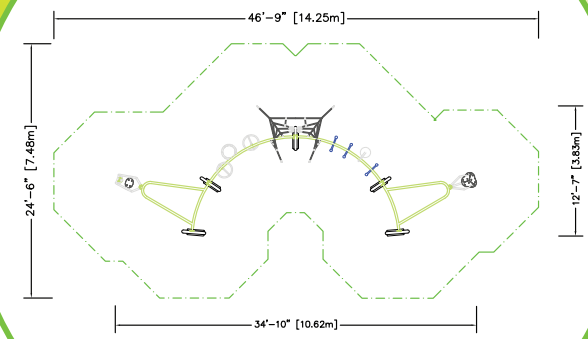

VELOCITY 4

VELOCITY 2 (1000NXVE2)	
Age range	7-14 yrs
EQUIPMENT DIMENSIONS	
Length x Width x Height - ft (m)	26'-7" x 12'-7" x 9'-10" (8.11 x 3.83 x 3.0)
INSTALLATION INFORMATION	
Total weight - lb (kg)	1,429 (648)
Heaviest part - lb (kg)	194 (88)
Largest part - ft (m)	12'-2" x 1'-2" x 3'-2" (3.73 x 0.35 x 0.96)
Concrete footings - yd ³ (m ³)	3.28 (2.51)
SURFACE & SPACE REQUIRED	
Min. space L x W x H - ft (m)	38'-6" x 24'-6" x 16'-5" (11.74 x 7.48 x 5.0)
Max. Fall Height - ft (m)	9'-10" (3)
Use Zone Area - ft ² (m ²)	647 (60)
Perimeter - ft (m)	110' (34)

VELOCITY 4 (1000NXVE4)	
Age range	7-14 yrs
EQUIPMENT DIMENSIONS	
Length x Width x Height - ft (m)	34'-10" x 12'-7" x 9'-10" (10.62 x 3.83 x 3.0)
INSTALLATION INFORMATION	
Total weight - lb (kg)	1,975 (896)
Heaviest part - lb (kg)	194 (88)
Largest part - ft (m)	12'-2" x 1'-2" x 3'-2" (3.73 x 0.35 x 0.96)
Concrete footings - yd ³ (m ³)	4.41 (3.37)
SURFACE & SPACE REQUIRED	
Min. space L x W x H - ft (m)	46'-9" x 24'-6" x 16'-5" (14.25 x 7.48 x 5.0)
Max. Fall Height - ft (m)	9'-10" (3)
Use Zone Area - ft ² (m ²)	807 (75)
Perimeter - ft (m)	132' (40)



NEXUS™ - ROCK CLIMB 'N' SLIDE

This distinctive set combines the popular activities of rock climbing and sliding into one unique, challenging design. Our **ROCK CLIMB 'N' SLIDE** features banister rails and a textured rock face positioned with handholds and footholds. The unit is available as part of **NEXUS VELOCITY 7** or as a stand-alone unit.

ROCK CLIMB 'N' SLIDE (1000NXRSE)	
Age range	7-14 yrs
EQUIPMENT DIMENSIONS	
Length x Width x Height - ft (m)	12'-2" x 6'-0" x 9'-10" (3.71 x 1.82 x 3.0)
INSTALLATION INFORMATION	
Total weight - lb (kg)	694 (315)
Heaviest part - lb (kg)	194 (88)
Largest part - ft (m)	12'-2" x 1'-2" x 3'-2" (3.73 x 0.35 x 0.96)
Concrete footings - yd ³ (m ³)	1.81 (1.38)
SURFACE & SPACE REQUIRED	
Min. space L x W x H - ft (m)	24'-2" x 17'-11" x 16'-5" (7.36 x 5.47 x 5.0)
Max. Fall Height - ft (m)	9'-10" (3)
Use Zone Area - ft ² (m ²)	337 (31)
Perimeter - ft (m)	71' (22)

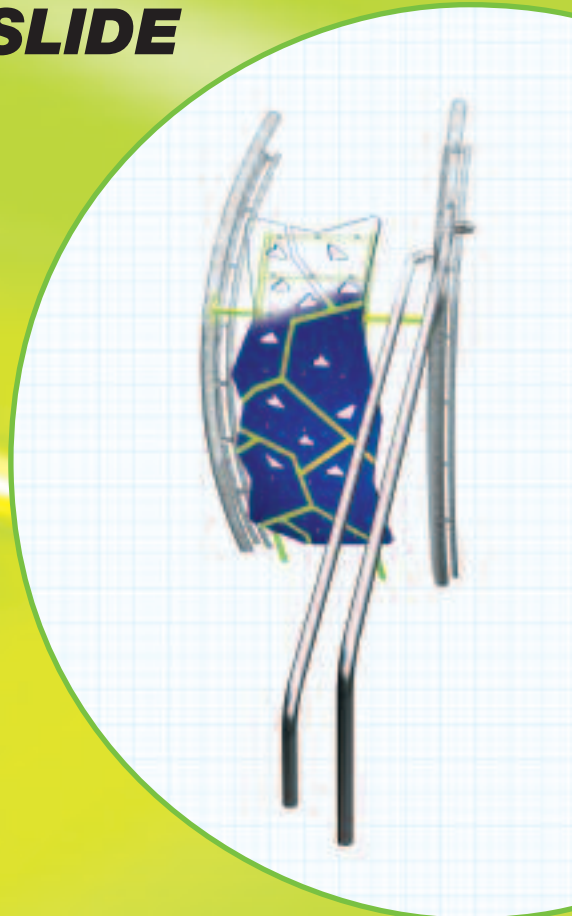
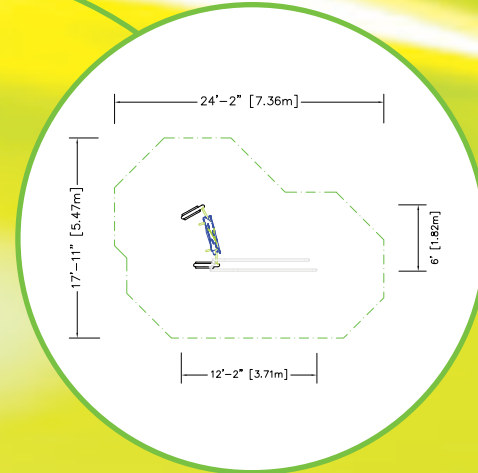

NEXUS™ - WHIZZER

NEXUS WHIZZER is a compact, modern-day update of the traditional playground spinning activity featuring an EkoGrip surface for comfort and safety. The sturdy platform handles spinning solo or easily accommodates a pair of riders facing each other for twice the fun.

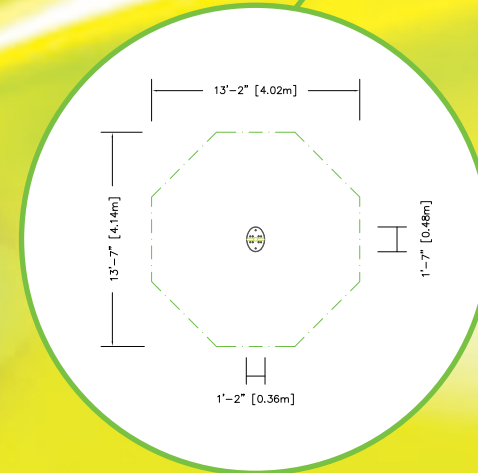

WHIZZER (1000NXWZE)	
Age range	7-14 yrs
EQUIPMENT DIMENSIONS	
Length x Width x Height - ft (m)	1'-7" x 1'-2" x 4'-3" (0.48 x 0.36 x 1.3)
INSTALLATION INFORMATION	
Total weight - lb (kg)	154 (70)
Heaviest part - lb (kg)	68 (31)
Largest part - ft (m)	1'-7" x 1'-2" x 4'-3" (0.48 x 0.36 x 1.3)
Concrete footings - yd ³ (m ³)	0.55 (0.42)
SURFACE & SPACE REQUIRED	
Min. space L x W x H - ft (m)	13'-7" x 13'-2" x 6'-11" (4.14 x 4.02 x 2.10)
Max. Fall Height - ft (m)	1'-0" (0.3)
Use Zone Area - ft ² (m ²)	145 (13)
Perimeter - ft (m)	44 (13)

NEXUS™ - QUANTUM

NEXUS QUANTUM is a compact junior counterpart to **NEXUS CORE**. Incorporating many of our popular **NEXUS CORE** features, including climbers, perches and a rock face anchored by two gantry posts, this unique combination packs a lot of play value into a small space.

QUANTUM (1000NXQE2)	
Age range	7-14 yrs
EQUIPMENT DIMENSIONS	
Length x Width x Height - ft (m)	8'-5" x 7'-1" x 9'-10" (2.56 x 2.15 x 3.0)
INSTALLATION INFORMATION	
Total weight - lb (kg)	736 (334)
Heaviest part - lb (kg)	194 (88)
Largest part - ft (m)	12'-2" x 1'-2" x 3'-2" (3.73 x 0.35 x 0.96)
Concrete footings - yd ³ (m ³)	1.37 (1.05)
SURFACE & SPACE REQUIRED	
Min. space L x W x H - ft (m)	20'-5" x 19'-1" x 16'-5" (6.22 x 5.81 x 5.0)
Max. Fall Height - ft (m)	9'-10" (3)
Use Zone Area - ft ² (m ²)	306 (28)
Perimeter - ft (m)	65' (20)

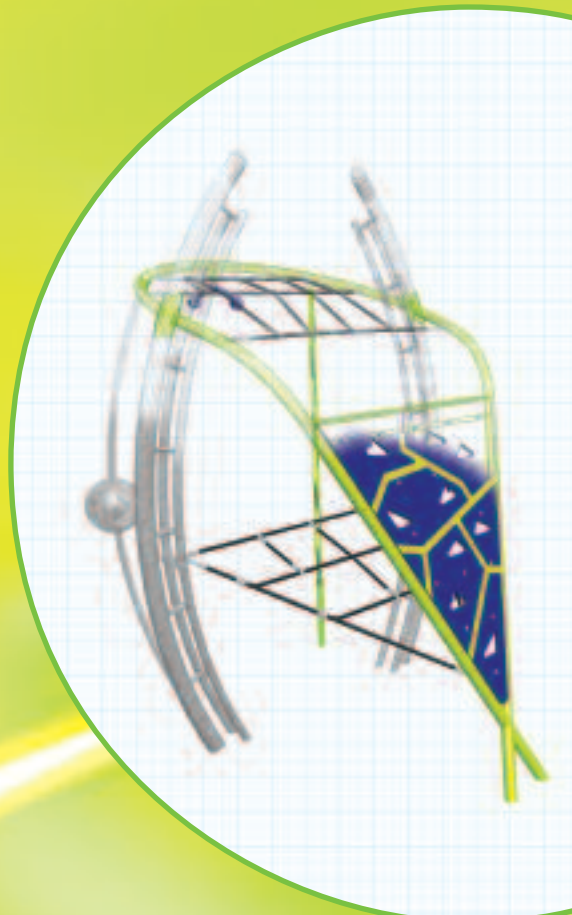
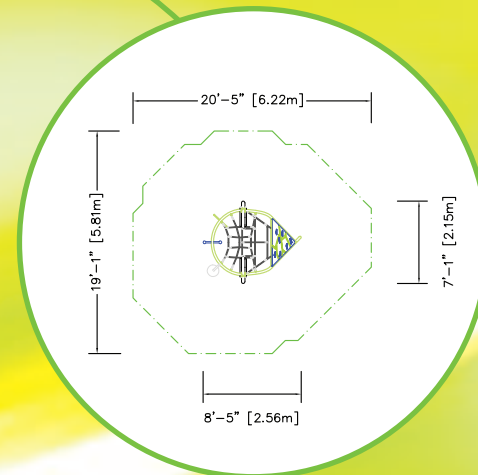

ARENA MEETING POINT

In addition to **NEXUS** playground equipment, SMP also offers an innovative line of **ARENA MEETING POINT** systems. Designed with eye-catching appeal for young people, the durable **ARENA MEETING POINT** is constructed from structural grade steel posts with a heavy-duty sheet steel roof and tamper-resistant stainless steel hardware. Color combinations include blue/silver and orange/purple. The unit shown is just one of many **ARENA MEETING POINTS** we offer – please visit www.playpower.com/nexus for our full range of available options and sizes.

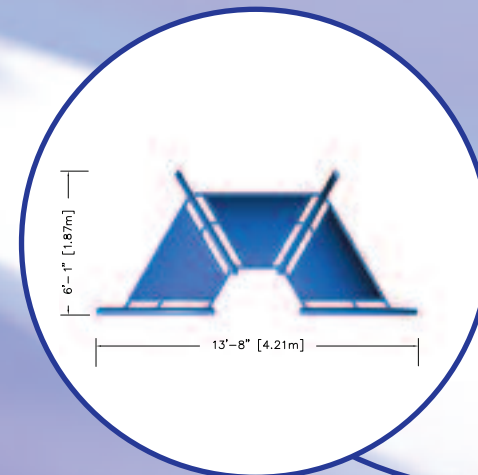

ARENA MEETING POINT - 3 SECTIONS (1MPSEAT30)	
EQUIPMENT DIMENSIONS	
Length x Width x Height - ft (m)	13'-8" x 6'-1" x 7'-1" (4.21 x 1.87 x 2.17)
INSTALLATION INFORMATION	
Total weight - lb (kg)	730 (331)
Concrete footings - yd ³ (m ³)	2.1 (1.60)

SMP, a PlayPower company, is the United Kingdom's leading manufacturer of children's playground and sports equipment. SMP has over 40 years experience in designing and building thousands of play areas across Europe and Asia, and is now launching our innovative new NEXUS product line to the United States.

Children's safety is our first priority, so these SMP products comply with ASTM F1487, CPSC and EN1176 industry standards.

Quality, innovative design, genuine durability and safety are the hallmarks of our products, making them the best you can find on the market today.

For additional information on our full line of SMP equipment, call **1-866-4PLAYPWR** or visit **www.playpower.com/nexus**.



Every Nexus product and Arena Meeting Point sold in the U.S. is designed and manufactured to meet or exceed the strictest guidelines and standards, including CPSC and ASTM. For documentation of third party certification, please contact your local sales representative.

*SMP is an ISO 9001:2000 Quality Assured Company
Certificate number FM10675*



1-866-4PLAYPWR
www.playpower.com/nexus

13620 E. Reese Blvd, Ste. 300 • Huntersville, NC 28078



PLAYPOWER